

BILL OF MATERIALS

ITEM	DESCRIPTION	QTY	MATERIAL
1	HANDWHEEL	1	WCB
2	NUT	1	CS
3	BOLT	2	CS
4	YOKE PART1	1	AISI 1020
5	LOCKING FLANGE	1	A216 WCB
6	LOCKING PIN	1	CS
7	STEM	1	410SS
8	NUT	2	CS
9	BOLT	2	CS
10	GLAND FLANGE	1	A216 WCB
11	PACKING	1	NBR
12	BODY PART1	1	AISI 1020
13	BODY PART 2	1	AISI 1020
14	SEAT	1	NBR
15	COVER FLANGE	1	A216 WCB
16	YOKE PART 2	1	AISI 1020
17	YOKE PART 3	1	AISI 1020

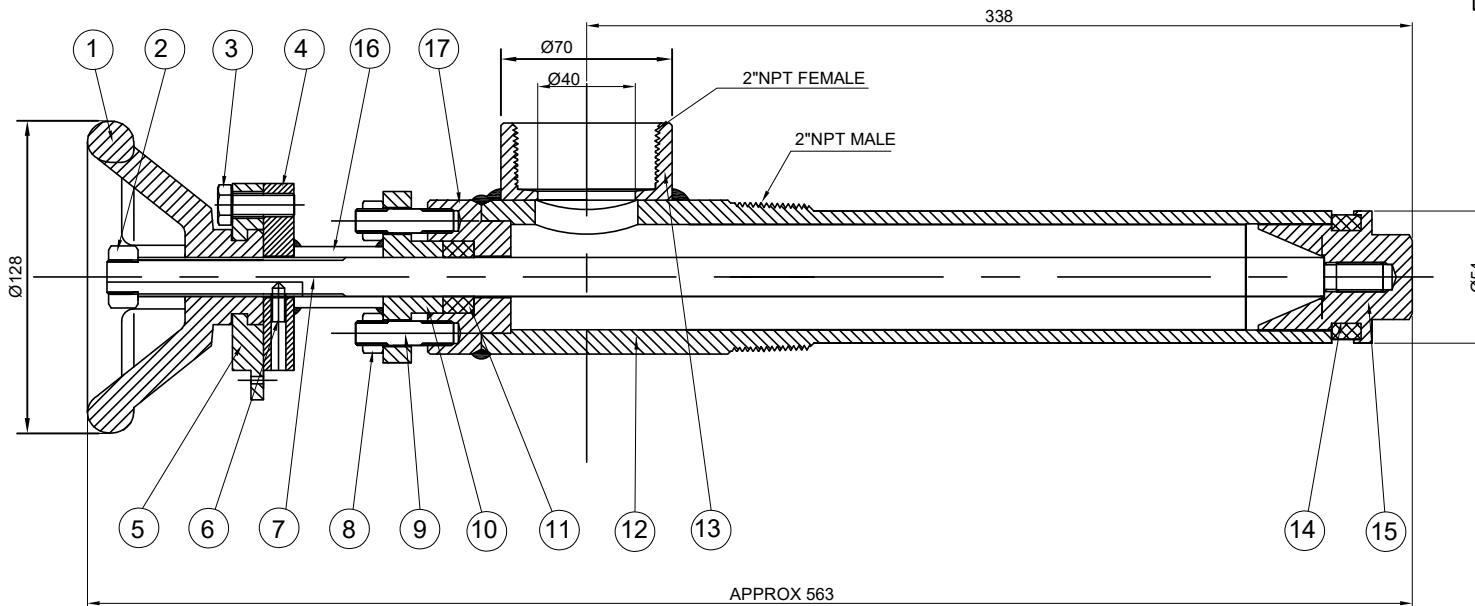

APPROX 563

Information on this drawing is the property of CNC Flow Control and may not be used or reproduced without express permission of CNC Flow Control.



C&C

CNC FLOW CONTROL

10350 Clay Road, ste 250
Houston, Texas 77041

Phone: 713-466-1644
Fax: 713-466-1715

	NAME	DATE
DRWN BY	KS	06.18.2018
CHK'D BY	JP	06.18.2018
APVD BY	-	-

2" - 150psi
NON - FREEZE TANK VALVE

UNIT: MM	SCALE	FIGURE NO.	REV.
-	-	NFTV - 2	A