



HAMMER UNIONS - FIGURE 100

C&C's Figure 100 is an economical union with precision machined metal-to-metal sealing surfaces. Recommended for water, oil and gas applications where working pressures do not exceed 1,000 PSI NSCWP.

* Interchangeable with other major manufacturers (see warnings on last page).



Specifications

- Sizes: 2" - 8"
- Pressure Rating: 1,000 psi NSCWP
- End Connections: Threaded & Butt-Weld
 - Butt-Weld Schedules: 40 (Std), 80 (XH)
- Color Code: Yellow Subs / Black Nut

Standard Service	
NSCWP	Test
1,000 psi	1,500 psi

**All working pressures are Non-Shock Cold Working Pressure Ratings (NSCWP) at ambient temperatures (-20°F to 100°F)*

Threaded End Connections

Nominal Pipe Size	2"	2.5"	3"	4"	5"	6"	8"
Part #	U010200	U012500	U010300	U010400	U010500	U010600	U010800
Material (Sub)	A105	A105	A105	A395 D.I.	A395 D.I.	A395 D.I.	A395 D.I.
Material (Nut)	A105	A395 D.I.	A105	A395 D.I.	A395 D.I.	A395 D.I.	A395 D.I.
Clearance Radius (A)	2.91"	3.66"	4.00"	4.69"	5.20"	6.97"	7.67"
End to End (B)	3.63"	4.38"	5.07"	6.24"	6.58"	7.10"	8.60"
Approx. Weight (lbs)	6.1	10.8	14.5	22.4	31.0	47.0	60.0
Box Quantity	16	8	6	4	2	1	1

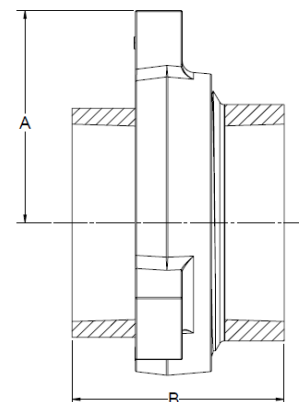

Butt Weld End Connections (Schedule 80*)

Nominal Pipe Size	2"	3"	4"	6"	8"
Part #	U010220	U010320	U010420	U010620	U010820
Material (Sub)	A105	A105	A105	A105	A105
Material (Nut)	A105	A105	A395 D.I.	A105	A395 D.I.
Clearance Radius (A)	2.91"	4.00"	4.69"	6.97"	7.67"
End to End (B)	3.79"	4.80"	4.98"	7.56"	7.31"
BW Sch 80 I.D. (ØC)	1.939"	2.900"	3.826"	5.761"	7.625"
BW Sch 80 O.D. (ØD)	2.375"	3.500"	4.500"	6.625"	8.625"
Approx. Weight (lbs)	6.6	16.0	23.5	54.0	80.0
Box Quantity	16	6	4	1	1

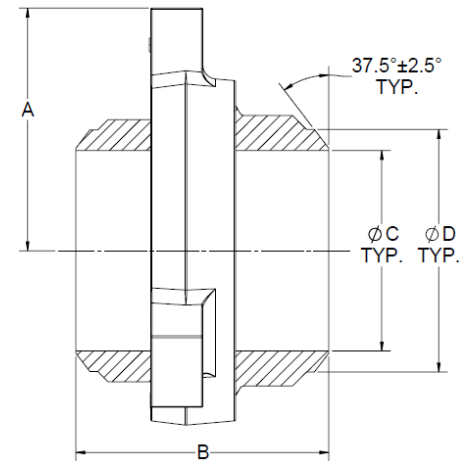

* Schedule 40 is available upon request

Full Hammer Union Offering

FIGURE #	COLOR CODING	PRESSURE RATING (psi)		NOMINAL PIPE SIZES													
		Standard Service		0.5"	0.75"	1"	1.25"	1.5"	2"	2.5"	3"	4"	5"	6"	8"	10"	12"
		NSCWP	Test														
100		1,000	1,500						☺	☺	☺	☺	☺	☺			
110		2,500 4,000	3,750 6,000						☺								
200		2,000	3,000			☺	☺	☺	☺	☺	☺			☺	☺	☺	
201		3,000	4,000						☺	☺							
206		2,000	3,000			☺	☺	☺	☺	☺	☺			☺	☺	☺	
207		2,000	3,000								☺	☺		☺			
26H		400	800								☺						
211		2,000	3,000						☺		☺						
300		2,000 2,500 12,500	3,000 3,750 18,750	☺	☺	☺			☺								
301		3,000	4,500						☺								
400		4,000	6,000						☺		☺	☺					☺
602		6,000	9,000			☺			☺	☺	☺	☺					
607 (CGC)		6,000	9,000						☺	☺							
1002		10,000	15,000			☺			☺	☺		☺	☺	☺	☺		
1003		7,500 10,000	11,250 15,000								☺	☺	☺				
1502		15,000	22,500			☺			☺	☺	☺	☺	☺				

 **PRODUCT WARNINGS** 

Failure to follow these warnings could result in failure and possible personal injury, death, or property damage:

- C&C products should be used only by qualified, trained individuals experienced in the safe and proper handling of hammer unions and other couplings. Users must follow all applicable specifications and industry best practices for the safe installation and use of C&C products.
- Never exceed the recommended pressure rating or mix components with different pressure ratings, as mismatched components can lead to failure under pressure, resulting in death, personal injury, or property damage.
- Never strike, tighten, or loosen pressurized components or connections.
- Never exceed the non-shock cold rated pressure (NSCWP) of the product. Complete and proper assembly of all components and connections is essential in order to attain the rated NSCWP.
- Never use any worn, eroded, or corroded components or connections. If any component of the union or connection is worn, eroded, or corroded, replace immediately.
- Never strike hammer unions that have deformed or flattened lugs.
- Never use C&C products in suspension applications.
- Never expose standard service components or couplings to sour gas fluids. Do not interchange sour gas components or couplings with standard service components or couplings.
- Always use extra care when working with carbon steel products in temperatures below 32°F/0°C. Freezing temperatures lower the impact strength of carbon steel.
- Always take all appropriate safety precautions and wear all appropriate protective equipment when assembling, disassembling, installing, or removing any C&C product.
- Always immediately remove from service any component or coupling from which leakage is detected.
- Carefully select the appropriate component or coupling for your intended use.
- Our standard unions are not dual certified for sour service/NACE applications. If you need a union for sour service/NACE applications, please let us know when you place your order.
- * If other manufacturers' components are used interchangeably, CNC Flow Control does not assume liability.