

DIAMOND GEAR

165WG180

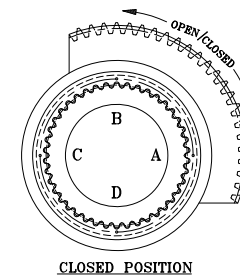
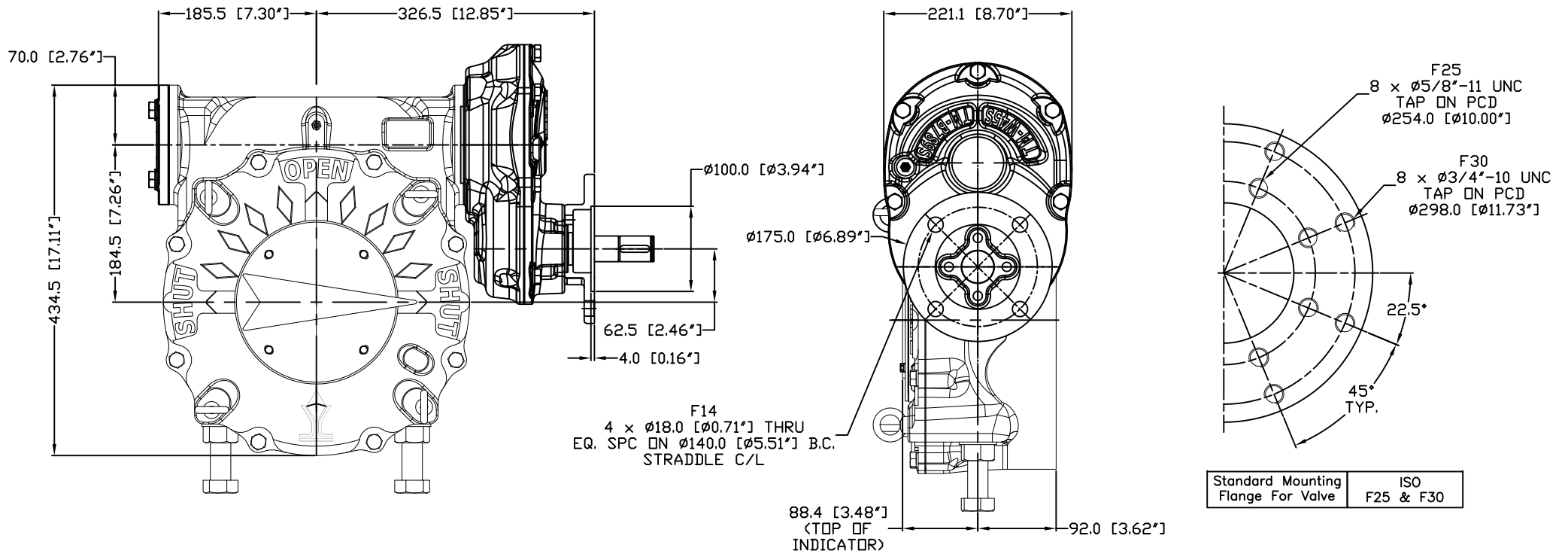

HW DIA.	RIM PULL AT MAX. I/P TORQUE (Lbs.)
28"	219

UNITS: MM [Inches]

MAX. OUTPUT TORQUE [IN.LB]	MAX. INPUT TORQUE [IN.LB]	RATIO	MECHANICAL ADVANTAGE	OUTPUT ANGULAR STROKE	TURN PER 90°	WEIGHT [LB]	MAX. ROUND BORE [IN.]	MAX. SQUARE BORE [IN.]	STANDARD MOUNTING STRADDLE C/L
165,331	3061	180:1	54	$\pm 20^\circ$	45	236	$\phi 4.50$ Key: 1 x 3/4	3.625	F25 & F30

C921247A 1/31/2019

CNC FLOW CONTROL
 HOUSTON, TEXAS, USA
 PHONE: 713-466-1644, FAX: 713-466-1715

REV.0